

Micro Self-reconfigurable Modular Robot using Shape Memory Alloy

Eiichi Yoshida* Satoshi Murata Shigeru Kokaji
Kohji Tomita Haruhisa Kurokawa

Mechanical Engineering Laboratory, AIST, MITI
1-2 Namiki, Tsukuba-shi, Ibaraki 305-8564 Japan
e-mail: eiichi@mel.go.jp

Abstract

This paper presents a micro-sized self-reconfigurable modular robotic system using shape memory alloy (SMA) actuators. Composed of identical robotic modules, the system can actively configure various structures. The motion of module is based on two-dimensional rotation by using an actuator mechanism with two SMA torsion coil springs. The micro-sized module measures 2cm cube and weighs 15g, half the size of the previous model developed so far. The feasibility of reconfiguration was demonstrated using the micro-sized robotic modules. We also show an extended three-dimensional (3D) model and discuss a distributed self-reconfiguration algorithm for large-scale modular structures.

Key Words: Self-reconfiguration, Modular Robotic System, Micro-robot, SMA Actuator

1 Introduction

We have developed a series of self-reconfigurable robotic systems composed of identical modules¹⁾⁻⁷⁾. By changing the configuration, these modular robotic systems can adapt themselves to the external environment or repair themselves by using spare modules without external help. Thus they have various potential applications, especially for structures or robots that should work in extreme environments inaccessible to humans, for instance, in space or deep sea, or in nuclear plants.

This paper focuses on developing a micro-sized self-reconfigurable robot aiming such applications as an inspection robot that moves around in very narrow space such as pipe space or in building destroyed by disaster. Although many studies have been made on self-reconfigurable robots⁸⁾⁻¹⁵⁾, their

*Corresponding author

micro-sizing has hardly been reported. We have so far developed a miniature self-reconfigurable modular robot using shape memory alloy (SMA) actuator¹⁶⁾. In this paper, we will present a new model of module that measures 2cm cube and weighs 15g, to demonstrate the advantage of easy micro-sizing of the simple SMA actuator mechanism. Its self-reconfiguration function is verified through an experiment of module motions. We will evaluate the measured performance of actuators to verify that they have enough torque for self-reconfiguration. An extended version of module that can configure three-dimensional (3D) structure will also be investigated and a distributed self-reconfiguration algorithm for large-scale system will be applied to the 3D model.

2 Micro-Sized Robotic Module

This section outlines the structure of micro-sized robotic module using SMA actuators. We have designed the modules' mechanism to be both self-reconfigurable and simple enough for micro-sizing. The module has a square shape, where two actuators at orthogonal vertices rotate male connecting parts that can be connected to female parts in another module. Figure 1(a)~(c) shows a "step motion," which is the most fundamental motion generated by two modules. Module M1 changes its relative position clockwise around M2 through appropriate operations of rotating actuators and connection mechanisms.

Although this step motion can be regarded as one simple function in the algorithmic level, it requires locally coordinated motion between neighboring modules based on inter-module communication in the hardware level. Figure 2 illustrates an example. When a module makes a step motion (clockwise or counterclockwise rotation), the module sends signals to neighboring modules so that the motion may be supported by rotating and releasing of appropriate male and female connecting

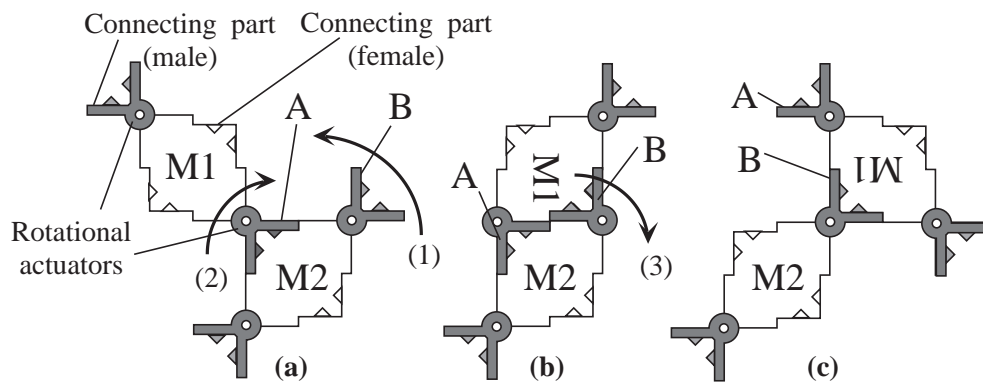

Fig. 1: Basic motion of two modules.

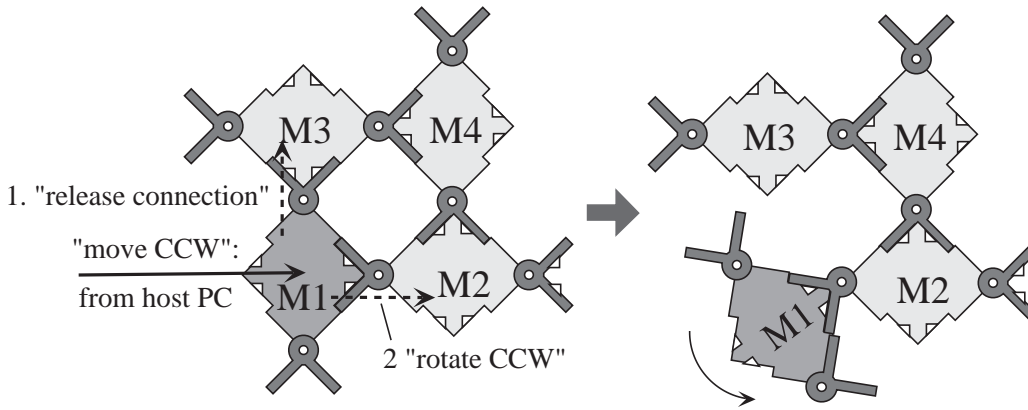

Fig. 2: Local motion coordination through inter-module communication.

parts. In this example, the module M1, intending to move counterclockwise, sends signals asking “releasing” to M3 and “rotate counterclockwise” to M2. Inter-module communication can be realized by embedding electrodes in male and female connecting parts.

By repeating these step motions, a collection of identical modules can construct various two-dimensional (2D) shapes. This homogeneous modular structure is also capable of self-repairing using spare modules if some part is damaged.

We adopted an SMA actuator mechanism for the micro-sized module. The SMA actuator generates torque based on strain energy and its torque-weight ratio is constant. This is advantageous especially on micro-scales compared to conventional electromagnetic motors whose torque-weight ratio decreases as their size becomes small ¹⁷⁾. Although it is known that the response of SMA actuators is relatively slow, this drawback can be overcome on micro-scales where the cooling efficiency is improved by increasing ratio of surface area to volume. Another shortcoming of SMA actuator, difficulty in precise control, is not a significant problem here since we need only discrete position control (-90° , 0° , 90°) in reconfiguration operation.

Figure 3 illustrates the developed rotational actuator dedicated for the micro-sized module. The SMA torsion coil springs (memorizing the 0° shape in this case) are pre-loaded by twisting reversely by 180° . Without heating, the static torques balance and no output torque is generated. In this state, the connecting part is fixed at the original 0° position by a mechanical stopper. Rotational motion is generated when one of the springs is heated, usually by electric current. Since Young’s modulus of SMA rises drastically when the temperature exceeds its phase transformation temperature, the heated spring generates a large torque in the direction to restore the memorized 0° rotation state.

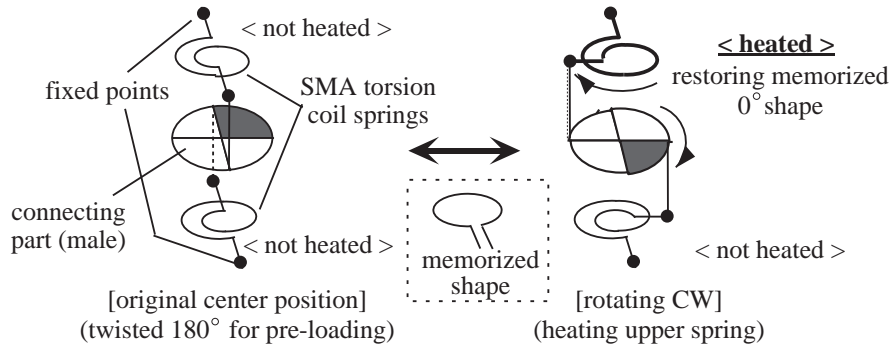

Fig. 3: Rotating actuator mechanism using SMA torsion coil springs.

3 Hardware Implementation and Experiments

This section presents development of micro-sized hardware modules and a self-reconfiguration experiment. We have so far developed a basic module model whose size is 5cm cube and whose weight is 80g including control unit, and verified its self-reconfiguration capacity using many modules¹⁶⁾. In pursuit of wider applications requiring motion or tasks in narrow spaces, we proceed further micro-sizing of modules. As mentioned in section 2, SMA actuator is advantageous in both torque-weight ratio and response especially on micro-scales. This section also evaluates the actuator performance of both models.

3.1 Micro-size Module

Figures 4 and 5 describe the design of a micro-sized module and a hardware prototype. The module measures approximately 2cm cube and weighs 15g without control unit. The square-shape module is equipped with two SMA actuators at the orthogonal vertices which rotate the drums (male connecting parts). The original 0° position of the rotating drum is maintained rigidly by a stopper mechanism

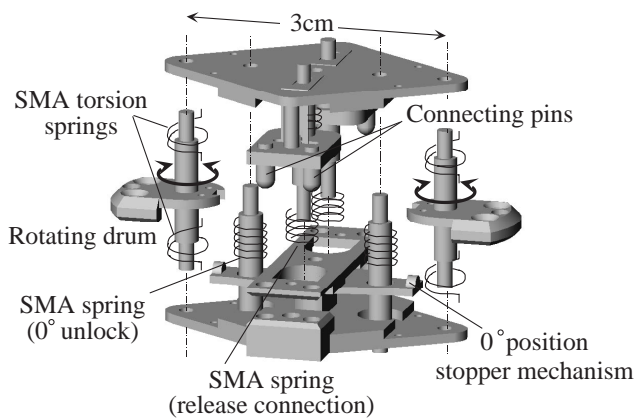

Fig. 4: Structure of micro-sized module.

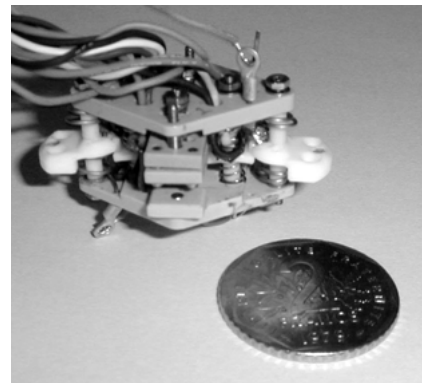

Fig. 5: Prototype of a module.

using plastic leaf spring as shown in Fig. 6. The rotation becomes possible when the stopper is pushed downwards by heating the SMA spring. As can be seen Fig. 6, the stopper also limits the drum rotation within the range from -90° to 90° . The female connecting part has an auto-locking mechanism that can hold and release (also driven by SMA) the drum of male connecting part (Fig. 7). Since the modules can maintain the structure mechanically by the above locking connection mechanism, the energy-consuming SMA heating is required only when some motion is made. Therefore, the whole energy consumption can be minimized even in many-module system because only the moving modules need the energy.

We adopt Ti-Ni-Cu SMA that has a large difference in Young's modulus of non-heated and heated condition, which leads to lower reverse torque from the non-heated spring. These SMAs are driven by PWM (50[Hz], duty ratio approximately 30%) through low-resistance MOS-FET from a PIC microprocessor module BasicStamp II, as shown in Fig. 8. It allows a module to serially communicate with the wired host PC as well as other connecting modules.

Figure 9 demonstrates the modules effectively realized the step motion in Fig. 1. In the current development, the micro-sized module does not yet include the onboard microprocessor and inter-module communication and is driven by a separate control unit. The integration of the controller and communication device into the module will be addressed in the future development.

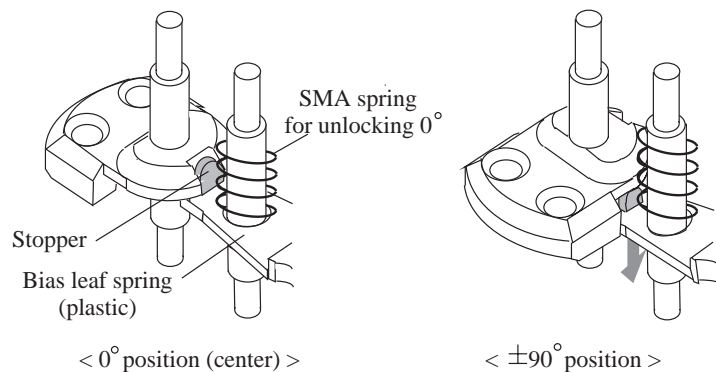

Fig. 6: Stopper mechanism of a male connecting part.

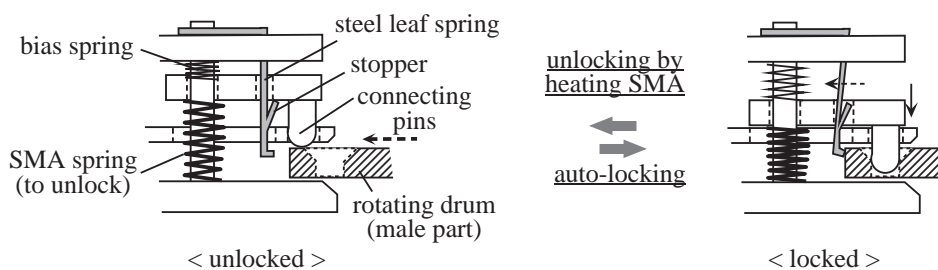

Fig. 7: Auto-locking mechanism of a female connecting part.

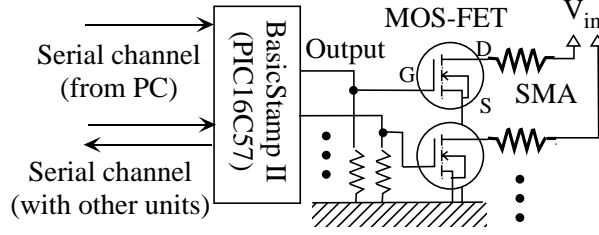

Fig. 8: Architecture of control unit.

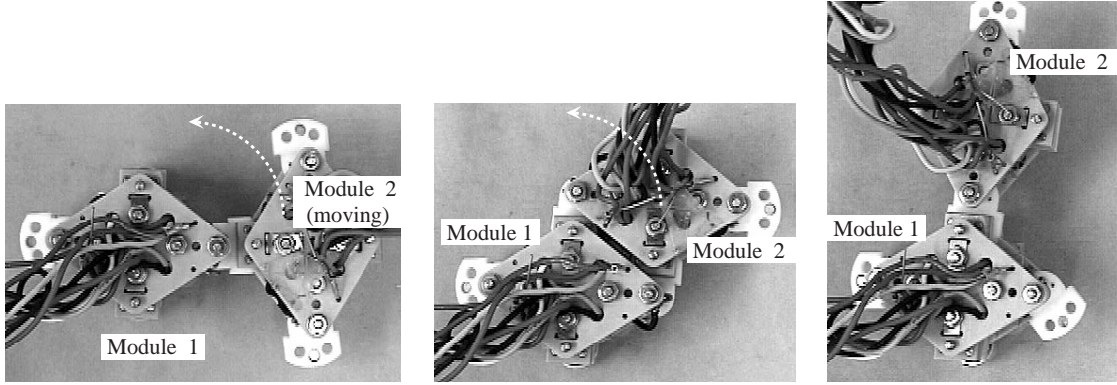

Fig. 9: Experiments of basic motion by two micro-size modules.

3.2 Performance Evaluation of Actuators

The output torque can be calculated for given rotational angle x° as follows ¹⁶⁾:

$$T = \frac{\pi d^4}{11520nD} \times \{E_2(B - x) - E_1(B + x)\} - f \quad (1)$$

where d and D [mm] are diameters of wire and spring, n the number of turns, E_1/E_2 [kgf/mm²] the Young's moduli in non-heated/heated condition, B° the angle by which both springs are twisted for pre-loading, f [kgf·mm] the rotational friction torque. Table 1 shows the specifications of SMA actuators utilized in two developed prototypes of micro-sized module. The Ti-Ni-Cu SMA has a large difference between $E_1(= 0 \sim 1800)$ and $E_2(= 7000 \sim 10000)$. Using these values, the range of the output torque can be estimated. With pre-loading angle $B = 270^\circ$, the range of output torque is calculated as shown in Table 1. The friction torque arises because the leaf spring of stopper mechanism (Fig. 6) is always pushed against the rotating drum (male connecting part). These values are measured in the hardware module using a torque gauge.

For example in the first model, the center of gravity is 20mm from the rotation axis and it weights approximately 80g, thus the required torque to lift another module against gravity is 1.6kgf·mm at rotational angle $x = 0^\circ$. Therefore, we can see the actuator can generate enough torque for self-reconfiguration. In the same way, we can estimate the actuator of micro-sized model has also sufficient torque, as the required torque for lifting motion is 0.2kgf·mm.

We have measured the generated torque by using torque gauge and the results are given in Table 2. As can be seen, the calculated torques of both models take values within the calculated ranges and the actuators generate sufficient torque for carrying another module. We are going to improve the performance by refining the design of module, for instance using micro-bearings to reduce the friction torque. As to the response time and power consumption, Table 2 shows that the time required for 90° rotation is reduced from 7 seconds to 5, and the current per one SMA actuator from 3A to 1A. This demonstrates that the micro-sizing of module improved these measures as indicated in section 2.

Table 1: Actuator specifications.

		Micro-size model	1 st model ¹⁶⁾
Wire diameter	d [mm]	0.45	0.8
Spring diameter	D [mm]	4.5	8.0
Number of turns	n	3	3
Friction torque	f [kgf·mm]	0.3	0.2
Calculated torque	T [kgf·mm]	0.9 ~ 1.9 ($x = 0^\circ$)	6.3 ~ 12.4 ($x = 0^\circ$)
		0.21 ~ 1.2 ($x = 90^\circ$)	2.6 ~ 8.2 ($x = 90^\circ$)

Table 2: Measured actuator performance.

		Micro-size model	1 st model
Torque T	(calculated)	0.9 ~ 1.9 ($x = 0^\circ$)	6.3 ~ 12.4 ($x = 0^\circ$)
		0.21 ~ 1.2 ($x = 90^\circ$)	2.6 ~ 8.2 ($x = 90^\circ$)
[kgf·mm]	(experiment)	1.1 ($x = 0^\circ$)	7.1 ($x = 0^\circ$)
		0.3 ($x = 90^\circ$)	3.0 ($x = 90^\circ$)
Time for 90° rot.		approx. 3 [sec]	approx. 7 [sec]
Current (mean, per actuator) [A] Voltage: 6 [V]		approx. 1	approx. 3

4 3D Extension and Distributed Self-Reconfiguration Software

This section first explains that the proposed modular robotic system can be extended to three dimensions, and next describes a distributed self-reconfiguration algorithm for many-module structure.

4.1 Extension to 3D Reconfigurable System

A three-dimensional (3D) module can be designed by extending the concept of the developed 2D module. First, the SMA rotational actuator mechanism is extended so that it can generate rotational motion along two orthogonal axes by using four SMA torsion coil springs as shown in Fig. 10. This corresponds to a male part and a connecting part should be equipped at one end. Next, a 3D module is constructed by embedding three of these connecting parts in a octahedral body including three female parts in such a way that all the motion directions are covered, as illustrated in Fig. 11. The female parts can be realized as a similar auto-locking mechanism to the developed 2D module. The body is designed so that collision between modules can be avoided during reconfiguration motion.

By connecting two modules as shown in Fig. 12, rotational motions in horizontal and vertical directions are possible around the connected vertex by means of a two-axis actuator. The SMA actuator should be designed to generate enough torque to achieve the desired motions.

Figure 13 illustrates the step motion by two 3D modules, where irrelevant actuators are omitted for clarity. Starting from the initial state Fig. 13a, the right-hand module changes its position to Fig. 13e through coordinated actuator operations. A group of modules can move on orthogonal-cubic lattice to form various 3D structures based on this step motion.

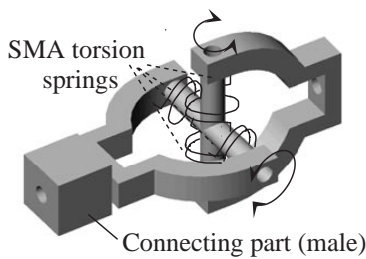

Fig. 10: Two-axis SMA actuator mechanism.

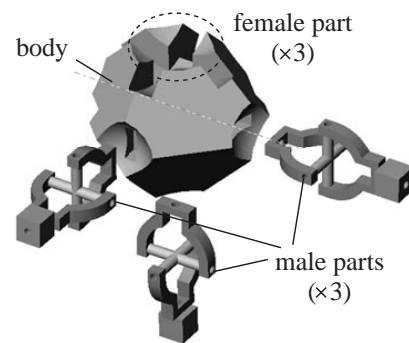

Fig. 11: A 3D module.

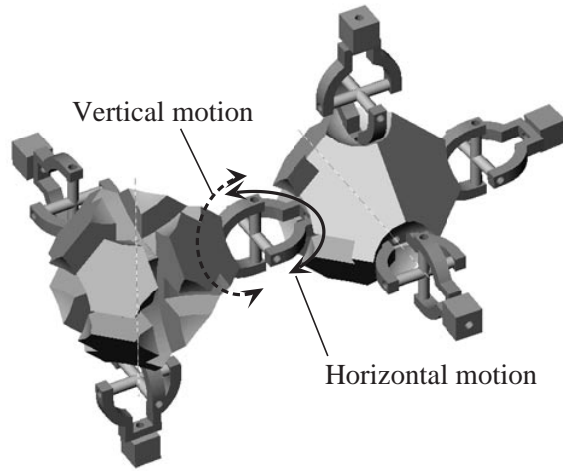

Fig. 12: Two modules connected.

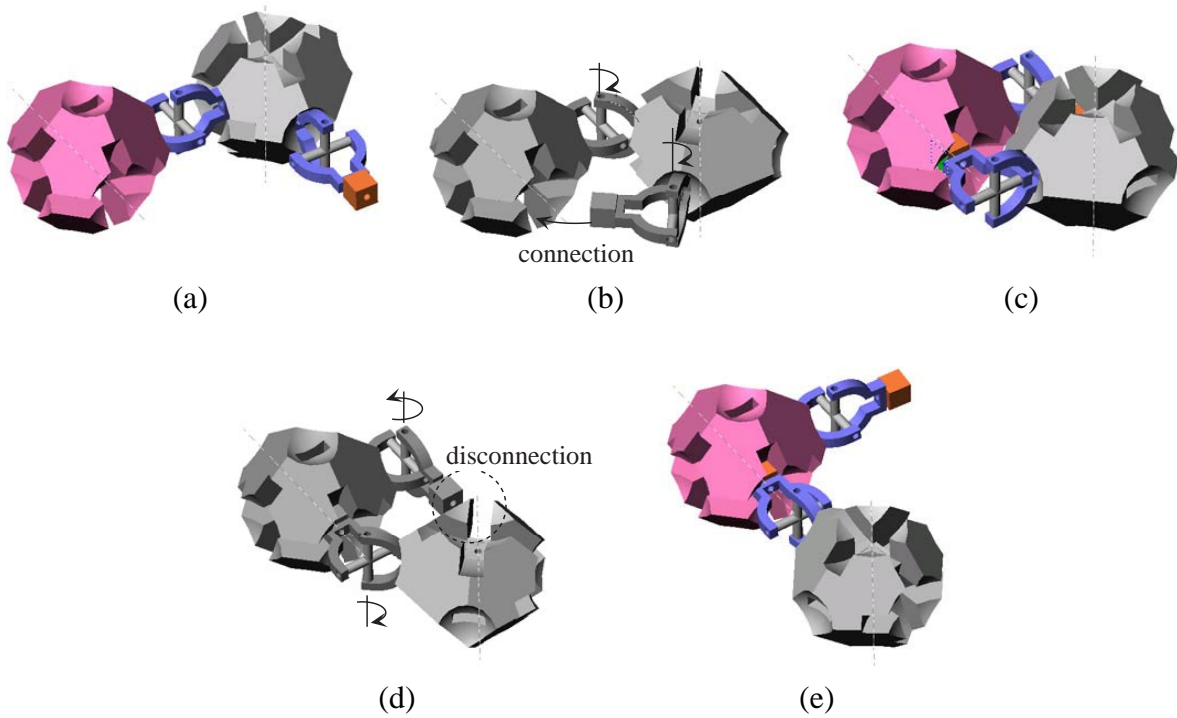

Fig. 13: Motion of 3D modules.

4.2 Distributed Self-reconfiguration of Many-Module System

As the motion of 3D SMA module is compatible to that of the 3D self-reconfigurable structure ^{2, 3)}, its distributed self-reconfiguration methods ⁵⁾ can be applied to the octahedral 3D modules. We have applied the distributed self-reconfiguration algorithm to small number of 3D SMA modules ¹⁶⁾ based on Markov Random Field (MRF). Although this simple algorithm has such advantages as low computational cost and communication load, it cannot be applied when the number of modules increases.

Table 3: Difference between algorithms for small-scale and large-scale systems

	small-scale (previous ¹⁶⁾)	large-scale (proposed)
System scale applicable	small (~ 10 modules)	large (10 modules \sim)
Target description	flat, for only simple shapes	hierarchical, for complicated shapes
Computational cost	low (simple MRF)	high (complicated target description)
Communication load	low (only few information on neighboring connection)	high (frequent message passing)

Here we introduce a distributed reconfiguration algorithm for large-scale system. Table 3 summarizes the difference between the algorithms for small-scale and large-scale systems. As explained in this table, the proposed algorithm is dedicated to self-assembly and self-repair of complicated shapes composed of many modules, say more than twenty modules.

Figure 14 illustrates the self-reconfiguration method for large-scale systems. It is based on a recursive description of the target shape by using a layered graph. Primitive description types are introduced that determine the geometrical relationship between “nodes,” denoting a group of modules here. By assigning another sub-structure to each nodes, various complex shapes can be described in a recursive manner. A module can belong to multiple levels in the course of self-assembly.

Given the description of a target shape, self-reconfiguration proceeds by assembling first top-level structure, then down to sub-structure and so forth, using inter-module communication. Figure 15 shows an example of self-assembly process of the 24-module planar shape from 27-module cube, where shaded modules have already reached a position in the target shape.

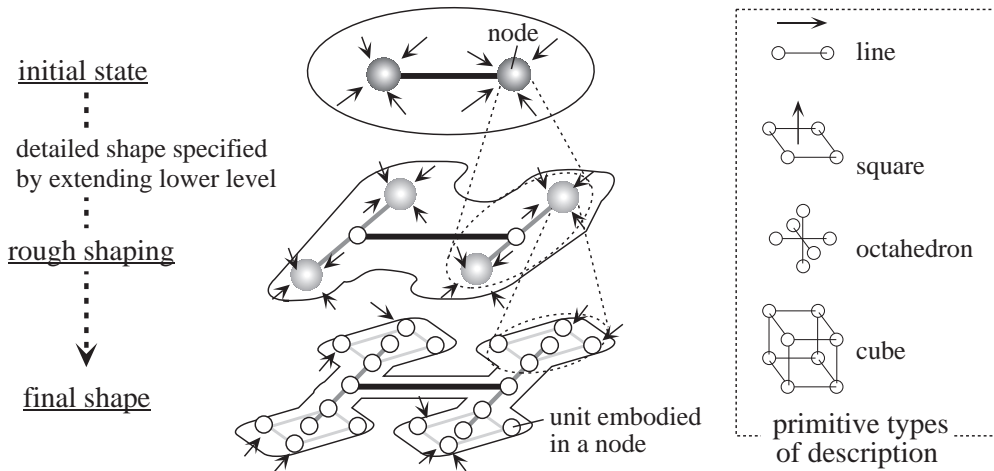

Fig. 14: Hierarchical graph structure for self-assembly.

Self-repair is also possible when some of the modules are lost or damaged. Upon the detection of fault, surrounding modules send messages to spare modules in order that they move and repair the faulty part. If the damaged part includes multiple modules in different levels of the target description, first the status of the modules involved in the self-repair is reset back to the relatively highest level in the target description. Then self-repair is performed from the higher level down to lower levels. Figure 16 shows a simulation result of self-repair after three modules have been removed.

The algorithm can be applied to small-size space structure such as solar panels or antennas. Transported in a compact folded form, they can expand themselves to the structure required by the mission, and repair themselves when failure or loss is detected somewhere in the structure.

5 Conclusions

This paper presented micro-sized self-reconfigurable robotic systems driven by SMA actuator mechanisms. The module is designed to allow a collection of identical modules to configure a variety of 2D structures. By using an actuator mechanism composed of SMA torsion coil springs, we realized micro-sized robotic modules that measure 2cm cube and weigh 15g. The self-reconfiguration

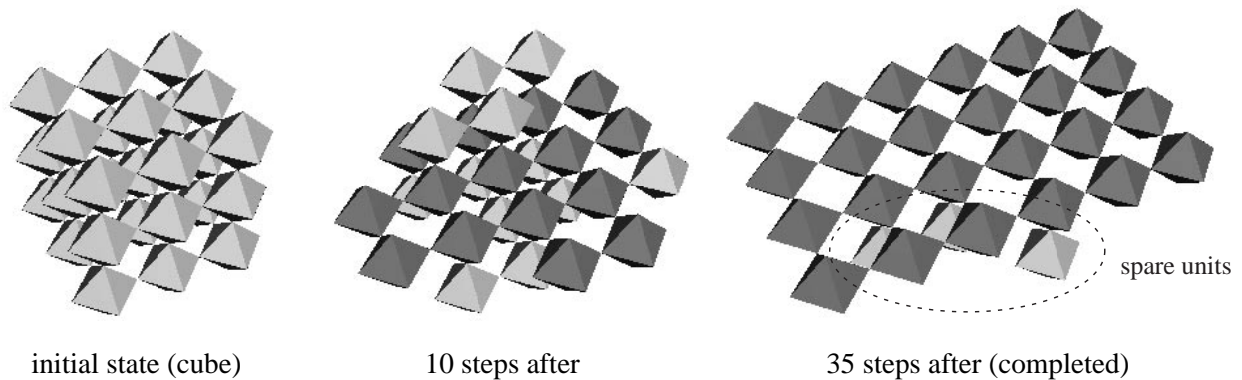

Fig. 15: Self-assembly of many-module structure.

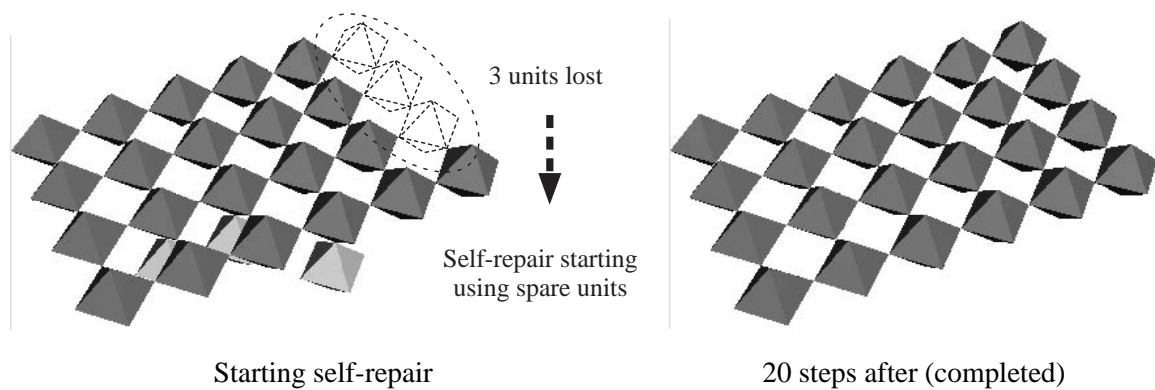

Fig. 16: Self-repair of many-module structure.

functionality was verified through a self-reconfiguration experiment using the developed hardware prototypes. The performance of the SMA actuators was also evaluated by measuring their output torque to confirm that they generate sufficient power. Furthermore, we designed an extended 3D self-reconfigurable robotic system based on the 2D module. It was shown that the self-reconfiguration and self-repair of large-scale systems is also possible by computer simulations.

References

- 1) S. Murata, et al.: "Self-assembling machine," *Proc. IEEE Int. Conf. on Robotics and Automation*, 441–448, 1994.
- 2) S. Murata, et al.: "A 3-D self-reconfigurable structure," *Proc. IEEE Int. Conf. on Robotics and Automation*, 432–439, 1998.
- 3) H. Kurokawa, et al.: "A 3-D self-reconfigurable structure and experiments," *IEEE/RSJ Int. Conf. on Intelligent Robots and Systems (IROS'98)*, 860–865, 1998.
- 4) E. Yoshida, et al.: "A distributed reconfiguration method for 3-D Homogeneous Structure," *Int. Conf. on Intelligent Robots and Systems (IROS'98)*, 852–859, 1998.
- 5) E. Yoshida, et al. : "A distributed method for reconfiguration of 3-D homogeneous structure," *Advanced Robotics*, Vol.13, No.4, 363–380, 1999.
- 6) K. Tomita, et al.: "Self-assembly and self-repair method for distributed mechanical system," *IEEE Trans. on Robotics and Automation*, Vol.15, No.6, 1035–1045, 1999.
- 7) S. Murata, et al. : "Self-reconfigurable Modular Robotic System," *Proc. Int. Workshop on Emergent Synthesis*, 113–118, 1999.
- 8) M. Yim: "New locomotion gaits," *Proc. IEEE Int. Conf. on Robotics and Automation*, 2508–1524, 1994.
- 9) G. Chirikjian, et al.: "Evaluating efficiency of self-reconfiguration in a class of modular robots," *J. of Robotic Systems*, Vol.12, No.5, 317–338, 1996.
- 10) G. Hamlin and A. Sanderson: "Tetrobot: A modular approach to reconfigurable parallel robotics," Kluwer Academic Publishers, 1998.
- 11) K. Kotay, et al.: "The Self-reconfiguring robotic molecule," *Proc. IEEE Int. Conf. on Robotics and Automation*, 424–431, 1998.
- 12) C. McGray and D. Rus: "Self-reconfigurable molecule robots as 3D metamorphic robots," *Proc.*

IEEE/RSJ Int. Conf. on Intelligent Robots and Systems, 837–842, 1998.

- 13) P. Will, et al. : “Robot modularity for self-reconfiguration,” *Proc. SPIE, Sensor Fusion and Decentralized Control in Robotic Systems II*, 236–245, 1999.
- 14) A. Casal and M. Yim: “Self-reconfiguration planning for a class of modular robots,” *Proc. SPIE, Sensor Fusion and Decentralized Control in Robotic Systems II*, 246–257, 1999.
- 15) C. Ünsal, et al. : “I(CDS)-cubes: a modular self-reconfigurable bipartite robotic system,” *Proc. SPIE, Sensor Fusion and Decentralized Control in Robotic Systems II*, 258–269, 1999.
- 16) E. Yoshida, et al.: “Miniaturization of Self-reconfigurable Robotic System using Shape Memory Alloy Actuator,” *J. of Robotics and Mechatronics*, Vol.12, No.2, 96–102, 2000.
- 17) K. Ikuta: “Micro/miniature shape memory alloy actuator,” *Proc. of IEEE Int. Conf. on Robotics and Automation*, 2156–2161, 1990.

Name:

Eiichi Yoshida

Affiliation:

Researcher, Systems Science Division, Department of Applied Physics and Information Science, Mechanical Engineering Laboratory, AIST, MITI

Address:

1-2 Namiki, Tsukuba, Ibaraki 305-8564 Japan

Brief Biographical History:

- 1990-1991 Research Student in Swiss Federal Institute of Technology at Lausanne (EPFL).
- 1993 M.Eng Degree (School of Engineering, University of Tokyo)
- 1996 Dr.Eng Degree (School of Engineering, University of Tokyo)
- 1996– Joined Mechanical Engineering Laboratory, AIST, MITI

Main Work:

- “Local Communication of Multiple Mobile Robots: Design of Optimal Communication Area for Cooperative Tasks,” Journal of Robotic Systems, Vol.15, No.7, 407–419, 1998.
- “An Experimental Study on a Self-repairing Modular Machine,” Robotics and Autonomous Systems, No.29, 79–89, 1999.

Membership in Learned Societies:

- The Institute of Electrical and Electronics Engineers (IEEE)
- The Japan Society of Mechanical Engineers (JSME)
- The Society of Instrument and Control Engineers (SICE)
- The Japan Society of Precision Engineers (JSPE)
- The Robotics Society of Japan (RSJ)

Name:

Satoshi Murata

Affiliation:

Senior Researcher, Systems Science Division, Department of Applied Physics and Information Science, Mechanical Engineering Laboratory, AIST, MITI.

Address:

1-2 Namiki, Tsukuba, Ibaraki 305-8564 Japan

Brief Biographical History:

1986 M.Eng Degree (Aeronautical Engineering, Nagoya University).

1997 Dr.Eng Degree (Aeronautical Engineering, Nagoya University).

1998–1999 Visiting researcher in Johns Hopkins University, USA

Main Work:

- “Self-Repairable Machine —Self-Assembling by Distributed Unit Structure—,” Trans. SICE, Vol.31, No.2, 254–262 1995 (in Japanese).
- “A 3-D self-reconfigurable structure,” Proc. IEEE Int. Conf. on Robotics and Automation, 432–439, 1998.

Membership in Learned Societies:

- The Society of Instrument and Control Engineers (SICE)
- The Japan Society of Mechanical Engineers (JSME)
- The Robotics Society of Japan (RSJ)
- The Institute of Electrical and Electronics Engineers (IEEE)

Name:

Shigeru Kokaji

Affiliation:

Director of the Department of Advanced Machinery, Mechanical Engineering Laboratory, AIST,
MITI.

Address:

1-2 Namiki, Tsukuba, Ibaraki 305-8564 Japan

Brief Biographical History:

- 1972 M.Eng. Degree (Dept. of Precision Machinery Engineering, the University of Tokyo)
- 1972– Joined Mechanical Engineering Laboratory, AIST, MITI
- 1981–1982 British Council Scholarship at Leicester Univ., UK
- 1986 Dr.Eng Degree (Dept. of Precision Machinery Engineering, the University of Tokyo)

Main Work:

- “Self-Organization of a Mechanical System,” Distributed Autonomous Robotic Systems, 237–242, Springer-Verlag, 1994.
- “Clock Synchronization Mechanisms for a Distributed Autonomous System,” J. of Robotics and Mechatronics, Vol.8, No.5, 427–434, 1996.

Membership in Learned Societies:

- The Japan Society of Precision Engineers (JSPE)
- The Robotics Society of Japan (RSJ)
- The Society of Instrument and Control Engineers (SICE)
- The Information Processing Society of Japan (IPSJ)

Name:

Kohji Tomita

Affiliation:

Senior Researcher, Machine Intelligence Division, Department of Applied Physics and Information Science, Mechanical Engineering Laboratory, AIST, MITI.

Address:

1-2 Namiki, Tsukuba, Ibaraki 305-8564 Japan

Brief Biographical History:

1990 M.Eng Degree (University of Tsukuba)
1990– Joined Mechanical Engineering Laboratory, AIST, MITI
1997 Ph.D Degree (University of Tsukuba)

Main Work:

- “Visual Navigation of an Autonomous Vehicle Along a Line,” Proc. Japan-USA Symp. on Flexible Automation, ASME, 1321–1327, 1992.
- “Self-assembly and self-repair method for distributed mechanical system,” IEEE Trans. on Robotics and Automation, Vol.15, No.6, 1035–1045.

Membership in Learned Societies:

- The Society of Instrument and Control Engineers (SICE)
- The Information Processing Society of Japan (IPSJ)
- Japan Society of Software Science and Technology (JSSST)

Name:

Haruhisa Kurokawa

Affiliation:

Head of the Sound and Vibration Division, Department of Advanced Machinery, Mechanical Engineering Laboratory, AIST, MITI.

Address:

1-2 Namiki, Tsukuba, Ibaraki 305-8564 Japan

Brief Biographical History:

1981	M.Eng Degree (University of Tokyo)
1981–	Joined Mechanical Engineering Laboratory
1990	Visiting Scientist at MIT, USA
1997	Dr.Eng Degree (University of Tokyo)

Main Work:

- “Exact Singularity Avoidance Control of the Pyramid Type CMG System,” Proc. AIAA Guidance, Navigation and Control Conf. AIAA-94-3559-CP, 170–189, 1994.
- “A 3-D Self-reconfigurable Structure,” Advanced Robotics, Vol.13, No.6, 591–602, 1999.

Membership in Learned Societies:

- The Society of Instrument and Control Engineers (SICE)
- The Japan Society of Mechanical Engineers (JSME)
- The Japan Society of Precision Engineers (JSPE)
- The American Institute of Aeronautics and Astronautics (AIAA)
- The Japan Society for Aeronautical and Space Sciences (JSASS)