

Standard Performance Test of Wearable Robots for Lumbar Support

Cota Nabeshima¹, Ko Ayusawa¹, Conrad Hochberg, and Eiichi Yoshida¹

Abstract—Wearable robots for lumbar support (hereafter, WRLS) can reduce the users' lumbar stress and the risk of their back injuries. Although several products have already been put on the market, consumers and distributors have difficulty comparing their performance during assistance because they are currently not measured in a standardized manner. To solve this problem, this letter designs a standard performance test for WRLS. In the test, a testing machine makes reference movements imitating trunk movements with knee and hip joints during manual handling such as lowering down, holding, and raising up. Then, two performance metrics: Assistive Torque Index (ATI) and Lumbar Compression Reduction (LCR) are evaluated. The human experiments show that the reference movements are ergonomically plausible to mimic the actual motion of humans. The robot experiments indicate the feasibility of the test itself. The performance test has already become a part of JIS B 8456-1:2017 (a Japanese product standard for WRLS) and is to be a part of ISO 18646-4.

Index Terms—Natural machine motion, performance evaluation and benchmarking, physically assistive devices, robot safety, wearable robot.

I. INTRODUCTION

WEARABLE robot technology is now applied in lumbar support applications. For instance, CYBERDYNE's HAL for Labor Support / Care Support (Lumbar Type) [1]¹ (hereafter, HAL), Innophysics's Muscle Suit [2] and ATOUN's MODEL A [3] (see Fig. 1) had been commercialized as of 2017. By generalizing these products, the wearable robots for lumbar support (hereafter, WRLS) can be characterized as the robots that,

- are attached to both thighs and, abdomen, chest and/or shoulders of the user e.g., with belts,
- output assistive torque which acts on thighs and the trunk of the user according to the user's input,

Manuscript received September 6, 2017; accepted February 12, 2018. Date of publication February 28, 2018; date of current version March 23, 2018. This letter was recommended for publication by Associate Editor H. Van der Kooij and Editor Y. Yokokohji upon evaluation of the reviewers' comments. This work was supported by METI. (Corresponding author: Cota Nabeshima.)

C. Nabeshima is with CYBERDYNE Inc., Ibaraki 305-0818, Japan, and also with CNRS-AIST Joint Robotics Laboratory, UMI3218/RL, National Institute of Advanced Industrial Science and Technology, Ibaraki 305-8560, Japan (e-mail: nabeshima_kota@cyberdyne.jp).

K. Ayusawa and E. Yoshida are with CNRS-AIST Joint Robotics Laboratory, UMI3218/RL, National Institute of Advanced Industrial Science and Technology, Ibaraki 305-8560, Japan (e-mail: k.ayusawa@aist.go.jp; e.yoshida@aist.go.jp).

C. Hochberg is with CYBERDYNE Inc., Ibaraki 305-0818, Japan (e-mail: conrad_hochberg@cyberdyne.jp).

Digital Object Identifier 10.1109/LRA.2018.2810860

¹HAL for Labor Support / Care Support (Lumbar Type) have been commercialized since 2014. As of the end of 2017, 1,074 devices were in use.



Fig. 1. CYBERDYNE's HAL for Labor Support (Lumbar Type), HAL for Care Support (Lumbar Type), Innophysics's Muscle Suit and ATOUN's MODEL A from the left.

- assist user's muscle forces to support the extending movements or keeping postures of the hip joints and/or the trunk, and,
- assist the users' action including movement of the body, posture keeping and/or object manipulation.

The WRLS typically support the users' trunk movements during manual handling such as lowering down, holding and/or raising up. In these movements, users' extension torque of trunk causes compressive force on his/her lumbar disks. When this compressive force exceeds their strength, tissue damage may occur which might evoke a degenerative process in the intervertebral disks eventually leading to low back pain. Based on this knowledge, the compressive force is used to estimate the risk of back injuries [4]. It means that the assistive torque provided by the WRLS will not only reduce the users' muscular effort of hip joints and/or trunk but also is expected to reduce the risk of their back injuries.

Occupational back injuries make the workers take time off to recover, so this converts to economic losses including medical costs. According to [5], in Japan as of 2011 the annual medical cost for occupational back injuries was estimated at about 80 billion JPY (about 800 million USD). These statistics tells us that the WRLS may potentially have a big impact, not only on the improvement of the workers' health and safety, but also on the economics.

By expecting this potential impact of the WRLS, the consumers and the distributors have great interest in such devices and would like to compare the performance of different WRLS. However, it turned out to be difficult to compare the WRLS in a fair manner, because the WRLS are a quite new product category and necessary information is not provided in a standardized manner from the manufacturers. This situation is not desirable in terms of growth of the market; therefore, the development of a standard performance test of the WRLS is becoming imperative.

To develop a standard performance test, the following issues should be addressed:

- Use only measured data by the testing machine and do not use internal information of the WRLS for objectivity,
- A performance metric should indicate the effective assistive torque changing over time in accordance with the movement and the input from the users,
- Another performance metric should quantify the major goal of WRLS, i.e., the reduction of the lumbar compression, and,
- Avoid human tests to obtain the same performance values wherever and whenever they are measured.

To solve these issues, by applying the new evaluation framework for human-assistive devices based on humanoid robotics [6], this letter proposes a performance test consisting of a testing machine, reference movements, and two metrics to indicate the performance of the WRLS, which are named Assistive Torque Index (ATI) and Lumbar Compression Reduction (LCR).

In this letter, Section II explains the newly designed testing machine. Section III formulates ATI and LCR as the performance metrics. The validation experiments for the reference movement with human subjects are in Section IV. The robot experiments to show the feasibility of the test itself are in Section V. Section VI discusses the limitations and future work. Finally, Section VII concludes this letter with the future outlook.

II. TESTING MACHINE

A. Requirements

To be a standard testing machine whose main components are a human-shape body dummy and actuators, it needs to satisfy the following requirements:

- The behavior and the measurement should be stable against any disturbances caused by the assistive torque;
- The operation, the data gathering and the data analysis should be easy for the operator;
- The dimension, shape and mass distribution of a human dummy should be within the plausible range based on literature or databases that are able to refer; and,
- To evaluate the performance of WRLS during its operation, the human dummy should be actively actuated and programmable and then realize the reference movements.

Although this letter applies the new evaluation framework for human-assistive devices based on humanoid robotics [6], using a humanoid robot as a standard testing machine is considered inappropriate in terms of development cost,² usability and repeatability. To address these problems, we designed a testing machine, whose specifications are described in the following subsections.

B. User Body Dummy

The crucial part of the standard testing machine is the user body dummy, to which WRLS is attached. To be a standard, the dimension, the shape, the mass distribution and the degree of freedom (DoF) of the dummy are important, because they affect

²According to an interview with testing laboratories, the purchasing cost should be about 5 million JPY (about 50 thousand USD).

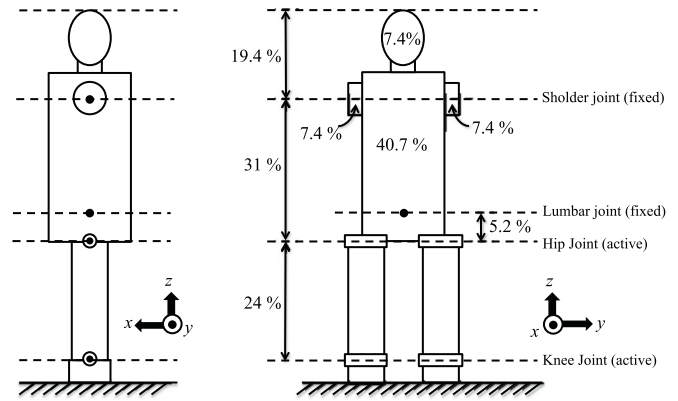

Fig. 2. The ratios of mass distribution and dimensions of the user body dummy. The actual masses and dimensions are calculated by setting the body height and body mass of a user as 100%.

the kinetics of the system consisting of a WRLS and the testing machine itself. However, they are very difficult to standardize, because those parameters of the humans vary widely.

To address this problem, this letter takes a ratio approach (Fig. 2). For simplification, the testing machine has one fixed lumbar joint and two active joints at knee and hip, which are the minimum configure for the movements assisted by the WRLS. Here, the following assumptions apply to simplify the lumbar and thoracic joints with a rigid structure:

- The flexion in the trunk itself is prevented by the erector spinae muscles; the compression forces on the lumbar disks due to activation of muscles will be calculated by applying the principle of virtual work (see Section III-C); and,
- The absolute angle of the rigid trunk can be used as an alternative value to the absolute angle from the lumbar joint to the center of gravity of the upper body when flexion at the trunk occurs (see also Section VI for the limitations).

The ankle joints are omitted in the dummy because the WRLS are not intended to assist them. The lumped masses apply for the mass of arms and hands by assuming that they are always directed downward during movements. The mass distribution and the dimension ratios come from Figure A.19 of IEC 60601-1 [7] except the dimension ratio between the hip joint and the lumbar joint. For the dimension ratio, 5.2% applies. This value is based on [8], where the distance ratio from a hip joint to L5/S1 spinal disk, where the back injury occurs most often, is approximately 83/1610 (5.2%) of the body height.

Because it varies more widely than the other parameters, the shapes of each body part are not specified in Fig. 2. Instead, they can be determined and customized freely to fit the WRLS being tested.

C. Reference Movements

Basically, the difference of measured values between with and without a WRLS attached to the testing machine could be seen as the performance of each WRLS. To achieve this approach, the standard testing machine should perform the same movements with and without a WRLS attached to it. Moreover, the movements should be ergonomically plausible to mimic the actual motion of humans. Additionally, the movement should consist of simply representations of parameterized trajectories

to avoid uncertainties from the optimization calculation, such as for minimal-jerk trajectories.

To satisfy the requirements, we define the trunk movements of lowering down, holding and/or raising up, which are typically seen in manual handling, as the reference movements and formulates their trajectories with the trunk angle θ_t , the hip joint angle θ_h and the knee joint angle θ_k as,

$$\theta_t(t) = at^5 - bt^4 + ct^3 + d, t = [0, t_d] \quad (1)$$

$$\theta_h(t) = k\theta_t(t) \quad (2)$$

$$\theta_k(t) = (1 - k)\theta_t(t) \quad (3)$$

where $\theta_t(t) = \theta_h(t) = \theta_k(t) = 0$ when the upright position. The starting time and the duration for each reference movements is 0 and t_d , respectively. The parameter k is a constant to represent the distribution ratio of the trunk angle to the hip joint and the knee joint. The parameters a , b , c and d will be calculated to satisfy the condition where $\dot{\theta}_t(0)$, $\dot{\theta}_t(t_d)$, $\ddot{\theta}_t(0)$ and $\ddot{\theta}_t(t_d)$ are all zero. Here, $\hat{\theta}_t(0)$ is the trunk angle at the end of the previous reference movement and $\theta_t(t_d)$ is the target trunk angle at the end of the current reference movement. The symbol “ $\hat{\cdot}$ ” means actually measured values.

The reference movements are to be done in sequence: from the upright position, lowering down, holding and then raising up. In this case, to generate the trajectories of the reference movements, the target trunk angle for the holding reference movement θ_t^{target} , t_d and k need to be determined. For the standard performance test, $\theta_t^{\text{target}} = 50$ [deg], $t_d = 2$ [s] and $k = 1.5$ should apply. The validation of these values and the formulation are provided in Section IV.

D. Controller

To actuate the dummy in accordance with the reference movements, a trajectory follow-up controller is needed. As a standard, it seems not adequate to restrict implementation of the controller because the controller should be customized with the actual actuation system to make its operation stable. Therefore, this letter just defines the requirement for the controller as the testing machine can follow the reference trajectories within ± 5 deg error even with WRLS. To make sure that the testing machine satisfies this requirement, the movements obtained during the test are to be checked afterwards; If this check fails, the parameters of the controller should be changed.

E. Input to WRLS

The input methods of WRLS allowing the users to control the assistive torque can be categorized into three types:

- **Biological signal input method:** input method where biological signals correlated to the user’s output force at the body part intended for assistance are used as the input, such as bioelectrical signals
- **Motional input method:** input method where motion and/or posture of the user’s body parts intended to be assisted are used as the input
- **Command input method:** input method where a control operation by the user is used as the input, such as input from command devices, breath switches, voice input or

motion and/or posture of the user’s body part not intended to be assisted.

Thus the testing machine needs to accept these input methods. For the motional input method, the movement itself coming from the user is used for the control of the WRLS. Therefore, the testing machine does not need any special input/output interface for the WRLS. For the biological signal input method, it needs to be able to output the extension torque information of its trunk to be correlated to the user’s output force. In case of the testing machine, the hip joint torque information can substitute it, because it has a rigid trunk. If the biological signal is not correlating with the user’s output force, the input method is to be considered as the command input method. For the command input method, because there is no direct physical relationship with the movement of the WRLS and the user, it is sufficient that the commands of the WRLS are executed according to the procedures described in the user manual.

F. Testing Procedure

The WRLS is to be attached to the testing machine in accordance with the user manual. The reference movements are to be done in the sequence: from the upright position, lowering down, holding and then raising up. For the test, this sequence is conducted three times iteratively. If intervals between the reference movements and/or mode changes are needed during the intervals, they can apply. The test will be suspended when a failure or a malfunction occur and make the test impossible to continue.

III. PERFORMANCE METRICS

A. Requirements

Performance metrics need to be measurable and, preferably, intuitive. Based on the purpose of the WRLS, the performance values of interest are the effects of the assistive torque during the movements: a) how much the user’s musculoskeletal effort will be reduced and b) how much the user’s lumbar stress will be reduced. Therefore, the formulation of the performances should be based on time-series data. To stabilize the calculation of the performance metrics, time integration techniques are applied. However, the integration ranges (time windows) should be feasible for what to evaluate. The following subsections show the formulation of the standard performance metrics that we designed.

B. ATI; Assistive Torque Index

To evaluate how much the user’s musculoskeletal effort will be reduced as the performance of a WRLS, it is reasonable to calculate effective assistive torque from the measurement. Based on this consideration, this letter formulates Assistive Torque Index (ATI)³ as (4) with the time window between t_1 and t_2 .

$$\text{ATI}_{t_2-t_1} = \frac{1}{t_2 - t_1} \int_{t_1}^{t_2} \psi(\hat{\tau}_h^{\text{ref}}(t), \hat{\tau}_h(t)) dt \quad (4)$$

³Although ATI is defined with the dimension of torque, the concept of torque is not common in consumers and distributors. To address this issue, JIS B 8456-1 adopted more consumer-friendly name “Assistive Force Criterion (AFC)” instead of ATI.

TABLE I
TIME WINDOWS TO EVALUATE ATI AND LCR

ATI	LCR	Reference movements	t_1 [s]	t_2 [s]
ATI ₁₀₀₀ ^{Lower}	LCR ₁₀₀₀ ^{Lower}	Lowering	$\hat{t}_d - 1$	\hat{t}_d
ATI ₂₀₀ ^{Lower}	LCR ₂₀₀ ^{Lower}	Lowering	$\hat{t}_d - 0.2$	\hat{t}_d
ATI ₁₀₀₀ ^{Hold}	LCR ₁₀₀₀ ^{Hold}	Holding	$\frac{\hat{t}_d}{2} - 0.5$	$\frac{\hat{t}_d}{2} + 0.5$
ATI ₁₀₀₀ ^{Raise}	LCR ₁₀₀₀ ^{Raise}	Raising	0	1
ATI ₂₀₀ ^{Raise}	LCR ₂₀₀ ^{Raise}	Raising	0	0.2

where $\hat{\tau}_h(t)$ is the measured output torque of the hip joint of the dummy with the assistance of the WRLS and $\hat{\tau}_h^{\text{ref}}(t)$ is that without the WRLS. Here,

$$\psi(x, y) = \begin{cases} x - y & \text{if } x \geq 0 \\ -(x - y) & \text{if } x < 0 \end{cases} \quad (5)$$

A positive ψ means that the extension torque (anti-gravity direction) of the WRLS reduces the user's extension (anti-gravity direction) torque or the user exerts the flexion torque (gravity direction) to suppress the extension torque of the WRLS. In contrast, a negative ψ implies that the output torque of the WRLS is in the flexion direction (gravity direction) and it increases the user's extension torque (anti-gravity direction).

If we directly apply the duration of each reference movement as the integration ranges, the time when only small assistive torque is needed is to be included; then, the values of ATI and LCR may become much lower than the maximum. We considered this is not suitable to indicate the performance of WRLS. Hence, we need to define reasonably short periods as a standard integration range.

In the reference movements, the end of the lowering down and the beginning of the raising up are the severest periods requiring the largest assistance from the WRLS. For this reason, to be a standard, t_1 and t_2 are defined for each reference movements as shown in Table I; ATI with 1-s duration is to represent how much assistive torque the WRLS can continuously output during these periods. On the other hand, ATI with 0.2-s duration focuses on a shorter time; This is used to evaluate how much the peak of the user's output torque is reduced by the WRLS.

C. LCR; Lumbar Compression Reduction

Ideally, the distance between the axis of the actuators of WRLS and the lumbar joint of the dummy can be seen as the distance between the fulcrums and then ATI can be converted to how much the moment around y-axis of the lumbar joint is reduced. However, the dynamic characteristics such as responsiveness, continuity and transmission efficiency of the assistive torque will effect the conversion. Therefore, it is reasonable to measure the stress at the lumbar joint and interpret it as the user's lumbar compression force.

In the human body, activating the back muscles is necessary to resist the movement caused by external torque. Thus the muscle activity creates a compression force on the spinal disks [4]. However, the fixed lumbar joint of the dummy does not allow a movement so the lumbar compression force can be corrected as (6), (7). Here, the moments around y-axis of the lumbar joint

are assumed to be supported by virtual erector spinae muscles and virtual abdominal rectus muscles.⁴

$$\hat{F}_z^{\text{ref}}(t) = \phi \left(\hat{M}_y^{\text{ref}}(t) \right) + \hat{F}_z^{\text{ref}}(t) \quad (6)$$

$$\hat{F}(t) = \phi \left(\hat{M}_y(t) \right) + \hat{F}_z(t) \quad (7)$$

$$\phi(x) = \begin{cases} x/0.05 & \text{if } x \geq 0 \\ -x/0.1 & \text{if } x < 0 \end{cases} \quad (8)$$

where $F(t)$ and $F^{\text{ref}}(t)$ are the corrected lumbar compression forces, $\hat{M}_y(t)$ and $\hat{M}_y^{\text{ref}}(t)$ are the measured y-axis moments at the lumbar joint, and $\hat{F}_z(t)$ and $\hat{F}_z^{\text{ref}}(t)$ are the measured z-axis compression forces at the lumbar joint. The superscript ^{ref} indicates the values are the reference obtained without the WRLS; The values without ^{ref} are obtained with the assistance of the WRLS. In (8), 0.05 m and 0.1 m are used as the representative distances from L5/S1 spinal disk to the erector spinae muscles and the abdominal rectus muscles, respectively [10], [11].

Using the corrected lumbar compression forces $F(t)$ and $F^{\text{ref}}(t)$, Lumbar Compression Reduction (LCR) is formulated as (9) with the time window between t_1 and t_2 .

$$\text{LCR}_{t_2-t_1} = \frac{1}{t_2 - t_1} \int_{t_1}^{t_2} \psi \left(\hat{F}_z^{\text{ref}}(t), \hat{F}_z(t) \right) dt \quad (9)$$

Here, ψ is the same function as defined in (5).

A positive ψ means that the assistance of the WRLS reduces the lumbar compression force during the reference movements; A negative ψ implies that the lumbar compression force increases due to the WRLS.

To be a standard, the same t_1 and t_2 as for ATI are used (See Table I). LCR with 1-s duration is to represent how much the user's lumbar compression force can be reduced continuously during these periods. On the other hand, LCR with 0.2-s duration focuses on a shorter time; this is to evaluate how much the peak of the user's lumbar compression force is reduced by the WRLS.

IV. VALIDATION OF REFERENCE MOVEMENTS

A. Objective

This section reports the validation results of the reference movements. At first, human movements are measured by a motion capture system. The captured movements are mapped on to the testing machine by the technology called motion retargeting [12]. The generated trajectories are interpolated by the 5th-order polynomial function shown in (1). Then, the errors between the original and interpolated trajectories are compared. The duration of motion t_d as well as the distribution ratio of the trunk angle to the hip and knee joints (i.e., parameter k in (2) and (3)) are validated.

⁴In order for this assumption to hold even in humans, supporting torque by passive tissues needs to be sufficiently small to the extent that the assistive torque is less than the torque by the active part (contractile elements) of the muscles. According to [9], the supporting torque by the passive tissues increases as the lumbar flexion increases e.g., 100 Nm with 100% lumbar flexion, 40 Nm with 80% and 25 Nm with 40%. Although the lumbar spine is omitted in the user body dummy, to model the corrected lumbar compression as (6), (7) the lumbar flexion needs to be assumed sufficiently small. see Section VI for further discussion and the limitations.

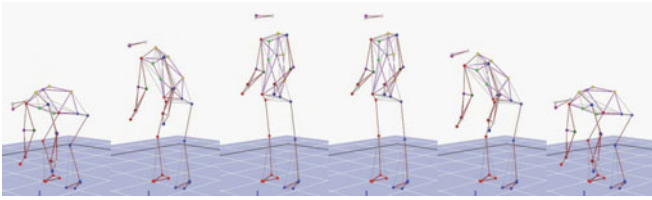

Fig. 3. Snapshots of captured human motion when lifting the highly light weight (0 kg) up and down.

B. Human Lifting Movement

As WRLS mainly assists hip joints and trunk, the human movements for lifting low-lying objects are focused on for this performance test. There are several types of lifting techniques when carrying objects [13], [14]. One typical way is stoop lifting; a person lifts up an object by using mainly his/her back muscles without bending the knees. Another approach is squat lifting that is performed by the leg muscles with the back straight. Squat lifting is commonly considered as a proper technique when lifting a heavy object. On the other hand, some studies show that stoop-type techniques are naturally selected by most people when lifting an object [14], [15]. The selected movements do not always mean the stoop lifting with knees perfectly straight. They also includes the semi-squat lifting: the midway posture between stoop and squat lifting [14].

Due to the objective of WRLS, the reference movements should take into account rather improper lifting movements to better estimate possible risks of the lumbar stress. It also needs to be considered that WRLS is used by various people including not only expert workers but also novices. In this sense, the reference movement should be the lifting movements that are naturally performed by people. Therefore, we selected natural semi-squat lifting as the reference movement.

C. Motion Retargeting and Interpolation

The semi-squat lifting movements of five human subjects were measured by a optical motion capture system provided by Motion Analysis Corporation. Each human subject was asked to lift up (raising movement) and down (lowering movement) three low-lying objects in a natural manner. In order to check the variation of motion with different weights, 0 (highly lightweight), 5, and 10 kg weights were lifted by each subject, respectively. The motion capture system measured the position of markers attached on human bodies. Fig. 3 shows snapshots of the captured movement when lifting 0 kg.

Human joint angles can be obtained from the measured marker trajectories by inverse kinematics computation. In order to design reference trajectories of the testing machine, the human joint trajectories need to be mapped on the machine. The testing machine has a simplified body structure with knee and hip joints and the different body dimensions from each human subject. Therefore, the human joint angles cannot be directly used for the referenced trajectory of the machine. In this letter, the motion retargeting technique shown in [12] was applied for translating the motions between each subject and the machine. The method utilizes the geometric parameters identification which can handle the different body dimensions between the two.

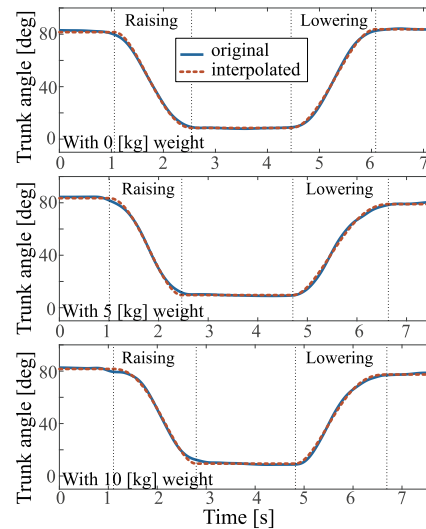

Fig. 4. Comparison of trunk posture angle trajectories. The top, middle, and bottom graphs show the trajectories when lifting 0, 5, and 10 kg weights, respectively. The blue lines indicate the original trajectories that are retargeted from the corresponding human motion. The red ones indicate the interpolated trajectories.

The retargeted trajectories for the testing machine were finally interpolated by 5th-order polynomial function that is shown in (1). If the initial and target angles of the trunk posture (i.e., $\theta_t(0)$ and $\theta_t(t_d)$) and the time duration t_d are given, the parameters a , b , c and d can be uniquely determined due to the boundary conditions of velocities and accelerations. The angles $\theta_t(0)$ and $\theta_t(t_d)$ and the time duration t_d were identified from the retargeted joint trajectories by nonlinear least square fitting. The distribution ratio k of the trunk angle was also computed from the trajectories of hip and knee joint angles.

D. Results

The raising and lowering movements with 0 kg, 5 kg, and 10 kg were retargeted, respectively. Then, the trajectories were interpolated by (1). The original retargeted trajectories of the trunk angles and the interpolated ones are plotted in Fig. 4. The top, middle and bottom graphs show the results of the sequenced lifting motion of one subject with 0 kg, 5 kg, and 10 kg, respectively. The blue line in each graph indicates the original retargeted trajectory of the trunk angle, and the red line means the interpolated one. As can be seen from Fig. 4, the original trajectories are well approximated by the polynomial interpolation with (1). Especially in the case of lifting 10 kg weight, small errors can be recognized in the original trajectory at the beginning and end of the raising movement ($t = 1, 3$ [s]). These errors seem to be derived from the balancing action when lifting a heavy object. Except for the timing when nearly losing balance, it is shown that 5th-order polynomial interpolation can approximate the trajectory of trunk posture angle during raising and lowering movements.

The identified values of time duration t_d among the five subjects when raising and lowering with each weight are also shown in Table II. The table indicates the mean, minimum and maximum value for each case. The time duration has various values among all cases. There were some difficulties to extract the exact timing when the human motion starts and stops. The duration

TABLE II
TIME DURATION t_d OF RAISING AND LOWERING MOVEMENTS AMONG
5 SUBJECTS WITH DIFFERENT WEIGHTS

Movement	Weight	Mean	Min.	Max.
Raising	0 kg	1.4 s	1.1 s	2.1 s
	5 kg	1.3 s	0.9 s	1.8 s
	10 kg	1.4 s	0.9 s	1.7 s
	0 kg	1.5 s	1.1 s	2.1 s
Lowering	5 kg	1.6 s	1.1 s	2.0 s
	10 kg	1.6 s	1.2 s	2.2 s
Overall		1.5 s	0.9 s	2.2 s

TABLE III
DISTRIBUTION RATIO k OF RAISING AND LOWERING MOVEMENTS AMONG
5 SUBJECTS WITH DIFFERENT WEIGHTS

Movement	Weight	Mean	Min.	Max.
Raising	0 kg	1.61	1.55	1.65
	5 kg	1.55	1.49	1.66
	10 kg	1.56	1.45	1.63
	0 kg	1.53	1.48	1.63
Lowering	5 kg	1.53	1.38	1.60
	10 kg	1.54	1.44	1.64
Overall		1.55	1.38	1.66

is also assumed to be affected by human intention. Though the total mean value of t_d is 1.5 s, from the viewpoint of accuracy and operation speed of the testing machine, the common value $t_d = 2$ [s] is finally considered for the standard performance test.

The distribution ratio k was also computed from the results of the interpolated trajectories. Table III shows the results of the obtained ratios among the five subjects in the case of raising and lowering with the three weights. The table indicates that the distribution ratio is not much affected by the weights. The ratio varies from 1.38 to 1.66, and its total mean value is 1.55. From those results, $k = 1.5$ is finally adopted for the standard performance test.

V. VALIDATION OF TESTING METHOD

A. Objective

To validate if the performance metrics can actually be evaluated, we created a testing machine satisfying the specification of Section II and conduct a trial with one WRLS.

B. Implementation of Testing Machine

1) *Mechanical Structure*: Fig. 5 indicates the testing machine we made. It consists of steel bones, steel weights to adjust the mass distribution, and 3D-printed covers to enable the WRLS to be attached. Assuming the case of lifting 0 kg, no additional weight was attached at the shoulder shaft.⁵ The

⁵This is because we could not standardize the weight of objects to be manually handled and we thought the weight does not effect on the resultant performance metrics. However, it can be tried by attaching an additional weight at the shoulder shaft, if needed.

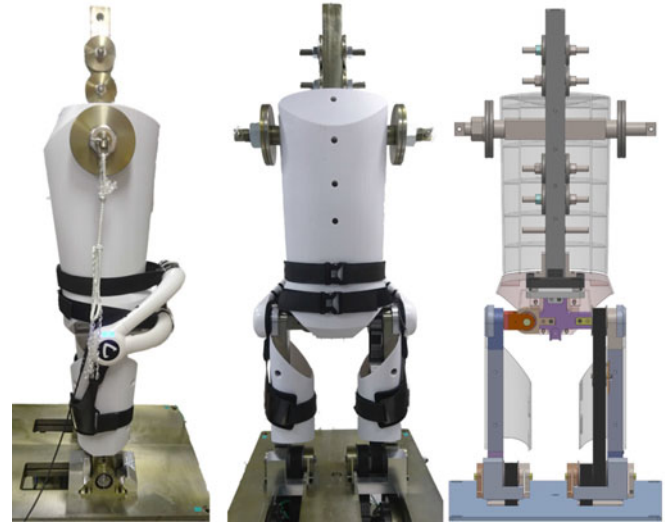

Fig. 5. Implementation of the testing machine with CYBERDYNE's HAL for Care Support (Lumbar Type) [1]. Left: the side view. Middle: the front view. Right: a sketch indicating the mechanical structure inside.

two 1.5 kW class actuators, which have maximum instantaneous torque and maximum continuous torque of 398 Nm and 133 Nm, respectively, are located under the base plate. One actuator's driving power is transferred to the right knee joint by a timing belt; the other is connected to the left hip joint via an additional timing belt at the left knee joint.

The shapes of the 3D-printed covers were obtained by simplifying the body shape of [8]. The covers are separated at the waist to take an accurate measurement of the lumbar stress by avoid a load distribution to the covers. The 2-axis force-torque sensor module is inserted at the lumbar joint. It consists of four 1-axis force sensors (KISTLER's 9021A) identical to the force plate. The torque of the testing machine is deduced from the output current of the actuator. The angles of the joints are measured by encoders built into the actuators.

2) *System Architecture*: PREEMPT_RT Linux was used to implement the control algorithm and a GUI. To obtain sensor data and to communicate with the servo amps, an EtherCAT I/O coupler was applied.

3) *Controller*: For the controller, a standard PD control algorithm was implemented. The P gain was set to 5,000 Nm/rad and the D gain was set to 500 Nms/rad for both of the actuators. Although these values were preliminary hand-tuned through a simulation, they satisfied the performance requirements of the controller (see Section II-D) and were applicable for the testing machine.

C. EUT; Equipment Under Test

HAL was used as an Equipment Under Test (EUT). It was attached to the testing machine in accordance with its user manual (Fig. 5). HAL exploits the user's bioelectrical signals (BES) to measure how much force he/she intends to exert as one of its control input. These signals are detected via skin electrodes on the erector spinae muscles. It also uses motion information from a built-in motion sensor. It, then performs necessary assistance without further manual operation. The maximum assistive torque is 30 Nm. The weight is around 3.0 kg, including a

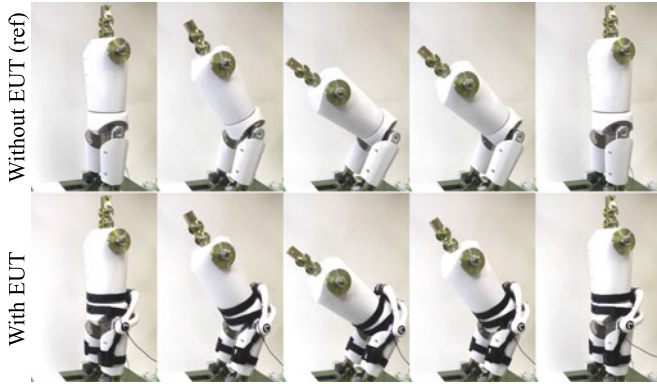

Fig. 6. Behaviors of the testing machine during reference movements without the EUT (top) and with the EUT (bottom).

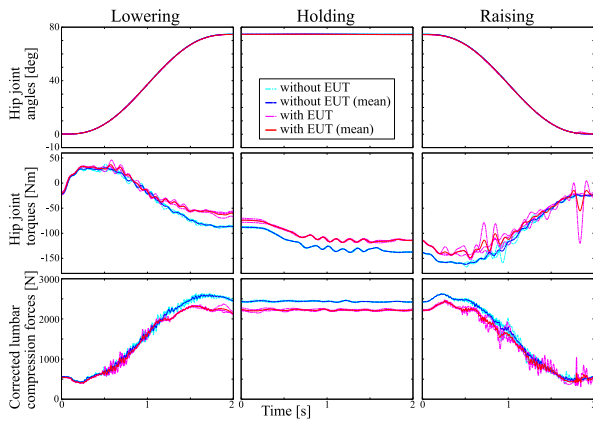

Fig. 7. Data obtained when the testing machine conducted the reference movements with the EUT (red lines) and without the EUT (blue lines): the hip joint angles (top), the hip joint torques (middle) and the corrected lumbar compression forces (bottom).

replaceable Li-ion secondary battery, whose rated operating time is 3 hours.

Because HAL requires BES input to operate, we made a special interface, which can convert the output torque of the hip joint actuator of the testing machine into an artificial BES. The interface receives the extension torque values of the hip joint actuator whose range is 0 to 200 Nm from Linux and generates to the 200 Hz differential sine signals with the peak amplitude of 60 μ V. The range of the torque was determined by rounding up the pre-measured maximum torque when the testing machine conducted the reference movements alone. The specification of artificial BES was determined by the input range of HAL.⁶ However, this conversion does not interfere with or manipulate the operation of the HAL, because HAL has an auto-calibration function of the BES input, which includes automatic scaling and offsetting.

D. Results

Fig. 6 illustrates the behaviors of the testing machine during the test. Fig. 7 shows the hip joint angles $\hat{\theta}_h(t)$, the hip joint torques $\hat{\tau}_h(t)$ and the corrected lumbar compression forces $\hat{F}(t)$

⁶If sensors of other WRLS can detect the artificial BES signal specified here, the same interface may apply as well.

TABLE IV
ATI AND LCR OBTAINED WITH THE TESTING MACHINE

ATI ₁₀₀₀ ^{Lower}	ATI ₂₀₀ ^{Lower}	ATI ₁₀₀₀ ^{Hold}	ATI ₁₀₀₀ ^{Raise}	ATI ₂₀₀ ^{Raise}
17.7 Nm	24.9 Nm	18.4 Nm	20.3 Nm	19.1 Nm
LCR ₁₀₀₀ ^{Lower}	LCR ₂₀₀ ^{Lower}	LCR ₁₀₀₀ ^{Hold}	LCR ₁₀₀₀ ^{Raise}	LCR ₂₀₀ ^{Raise}
193 N	300 N	215 N	195 N	227 N

obtained when the testing machine conducted the reference movements with the EUT (red lines) and without the EUT (blue lines). The graph overlays three trials for each reference with thin lines and their average with thick lines.

Fluctuations are observed in the hip joint torques and the corrected lumbar compression forces of Fig. 7. They were about 30 Hz based on frequency analysis and considered due to natural oscillation frequency of the testing machine. Practically, this pulsation can be filtered with a low-pass filter whose cut-off frequency is 10 Hz.

After applying the zero-phase 9th-order low-pass Butterworth filter with the cut-off frequency of 10 Hz for the data indicated in Fig. 7,⁷ the ATI and LCR were calculated with (4) and (9). Table IV describes the resulting ATI and LCR.

E. Discussion and Conclusion

By reviewing the results of Section V-D, we can conclude that this testing machine was able to perform the reference movements and evaluate the performance metrics. The values of ATI and LCR are reasonable in accordance with HAL's maximum assistive torque 30 Nm and its input method.

If we could assume the ideal condition where the axis of the actuators of HAL are always aligned with the lumbar joint and the transmission efficiency of the assistive torque is always 100%, all LCR should be equal to ATI/0.05 (0.05 m is the moment arm between the lumbar joint and the virtual erector spinae muscles. See also Section III-C). However, all LCR were in the range between 50% and 60% of ATI/0.05 according to Table IV. It suggests the transmission efficiencies of HAL during all the time of the reference movements are in the range between 50% and 60%. This fact also supports the necessity of the two different performance metrics for WRLS.

VI. DISCUSSION

To achieve objective evaluation of performance of WRLS, this letter proposed the testing method, the testing machine and the two performance metrics: Assistive Torque Index (ATI) and Lumbar Compression Reduction (LCR). Although we believe they reflect the dynamic characteristics of WRLS alone and are helpful for consumers and distributors, it is important to note their limitation; The performance values of ATI and LCR are not identical to the assistive torque and the reduction of the lumbar compression force received by a living human user.

We think the major modeling error source is the user body dummy (Fig. 2). It omits the lumbar spine and the soft tissues influencing the transmission of the assistive torque. To be more biomechanically feasible, the dummy should allow the flexion

⁷From the filter characteristics, the effect of the filtering on the resultant performance metrics were considered neglectable.

of the lumbar spine and the dynamic load distribution on the soft tissues. Although it seems quite difficult to realize such a testing machine because of the complexity in mechanical structures, materials and controls, we believe it is worth investigating as a next step of this letter. The literature [16] may give insight here.

Another limitation comes from the lack of evaluation of contact force between WRLS and a body surface i.e., skin. The contact pressure on the skin is known as a source of skin abrasion, internal bleeding and discomfortability. If we would like to see it as a performance of WRLS alone, the user body dummy should implement soft tissues including skin-like pressure sensors. This is also another next step of this letter.

In this letter, we selected the semi-squat movement as the most natural lifting. As for stoop lifting, it is usually not recommended to protect the lumbar region. We assumed this situation is the same even when using WRLS. On the other hand, squat lifting is preferable but it is not always applicable in natural situations. Moreover, WRLS are not expected to reduce the lumbar compression when the absolute angle of trunk is near upright. Based on these considerations, we selected semi-squat movement as the reference movement (Section IV-B). However, the further evaluation in the cases of squat lifting and squat lifting may be helpful to understand the performance of WRLS. This could be the most possible next step of this letter.

The testing machine of this letter receives assistance from WRLS to achieve its movement. This is unusual for testing machines. Instead, the parameters of the controller to actuate the user body dummy (Section II-D) may somewhat influence the resulting ATI and LCR. Additionally, we need to further investigate on the influence on stability margins and fluctuations in forces and torques in the future.

VII. CONCLUSION

To meet the needs of market for wearable robots for lumbar support (WRLS), this letter proposed a performance test including a testing machine and performance metrics. We also provided the validation of the test itself by two experiments with human and with WRLS.

Most importantly, this performance test constitutes a part of a national standard of Japan named JIS B 8456-1 [17], which specifies performance requirements, safety requirements and indication requirements of WRLS based on a consensus between manufacturers, consumers and other neutral bodies (national research institutes and certification bodies). Furthermore, currently we are developing an international standard named ISO 18646-4 based on our performance test at ISO/TC299/WG4. We hope that, in the future, manufacturers around the world will evaluate the performance of their WRLS in accordance with the test in this letter and be able to provide clear results to their users and customers.

The standard JIS B 8456-1 and ISO 18646-4 are limited to WRLS only, that is, only applicable to actively assisting exoskeletons. However, our performance test does not require the EUT to be an active device. Therefore it can be applied even if the EUT is a passively assisting exoskeleton for lumbar support such as Laevo V2 [18].

Although our performance test can provide a stable performance evaluation by eliminating human factors, in a broader context, performance of the WRLS can also be based on a use

test e.g., operating time or metabolic rate of real human users in the real work. In this case, it is more adequate to use subjective evaluation methods or impact evaluation methods than using a testing machine. Of course, there are no standard humans or standard work environments. Thus we need to perform extensive research in the future for establishing a standardized evaluation test with these other use test methods. Finally, if a correlation between these other test methods and the performance metrics provided by this letter can be determined, the benefits for the users and customers of the WRLS will be even greater.

ACKNOWLEDGMENT

The authors present sincere gratitude to Mr. Makoto Oashi of JSA and Mr. Hirokazu Sano and Ms. Namiki Okamoto of METI for their precious advice on standardization.

REFERENCES

- [1] CYBERDYNE Inc., Tsukuba, Japan, "HAL for Labor Support/Care Support (Lumbar Type)," 2014. [Online]. Available: <https://www.cyberdyne.jp/english/>
- [2] Innophys Co., Ltd., Tokyo, Japan, "Muscle Suit." 2014. [Online]. Available: <https://innophys.jp/product/>
- [3] ATOUN Inc., Nara, Japan, "ATOUN MODEL A." 2015. [Online]. Available: <http://atoun.co.jp/products/atoun-model-a>
- [4] T. Waters, V. Putz-Anderson, A. Garg, and L. Fine, "Revised NIOSH equation for the design and evaluation of manual lifting tasks," *Ergonomics*, vol. 36, no. 7, pp. 749–776, 1993.
- [5] H. Itoh, F. Kitamura, and K. Yokoyama, "Estimates of annual medical costs of work-related low back pain in Japan," *Ind. Health*, vol. 51, no. 5, pp. 524–529, 2013.
- [6] K. Ayusawa, E. Yoshida, Y. Imamura, and T. Tanaka, "New evaluation framework for human-assistive devices based on humanoid robotics," *Adv. Robot.*, vol. 30, no. 8, pp. 519–534, 2016.
- [7] *Medical Electrical Equipment—Part 1: General Requirements for Basic Safety and Essential Performance*, Standard IEC 60601-1:2005+AMD1:2012, 2012.
- [8] Y. Nakamura *et al.*, "Skeletal shape data of an adult male," AIST H20PRO-905, 2008.
- [9] P. Dolan, A. Mannion, and M. Adams, "Passive tissues help the back muscles to generate extensor moments during lifting," *J. Biomech.*, vol. 27, no. 8, pp. 1077–1085, 1994.
- [10] D. B. Chaffin, "A computerized biomechanical model—Development of and use in studying gross body actions," *J. Biomech.*, vol. 2, no. 4, pp. 429–441, 1969.
- [11] M. J. Jorgensen, W. S. Marras, F. W. Smith, and M. H. Pope, "Sagittal plane moment arms of the female lumbar region rectus abdominis in an upright neutral torso posture," *Clin. Biomech.*, vol. 20, no. 3, pp. 242–246, 2005.
- [12] K. Ayusawa, M. Morisawa, and E. Yoshida, "Motion retargeting for humanoid robots based on identification to preserve and reproduce human motion features," in *Proc. IEEE/RSJ Int. Conf. Intell. Robots Syst.*, 2015, pp. 2774–2779.
- [13] J. van Dieen, M. Hoozemans, and H. Toussaint, "Stoop or squat: A review of biomechanical studies on lifting technique," *Clin. Biomech.*, vol. 14, pp. 685–696, 1999.
- [14] L. Straker, "Evidence to support using squat, semi-squat and stoop techniques to lift low-lying objects," *Int. J. Ind. Ergonom.*, vol. 31, no. 3, pp. 149–160, 2003.
- [15] M. Authier, M. Lortie, and M. Gagnon, "Manual handling techniques: Comparing novices and experts," *Int. J. Ind. Ergonom.*, vol. 17, no. 5, pp. 419–429, 1996.
- [16] N. Arjmand, D. Gagnon, A. Plamondon, A. Shirazi-Adl, and C. Larivière, "Comparison of trunk muscle forces and spinal loads estimated by two biomechanical models," *J. Clin. Biomech.*, vol. 24, no. 7, pp. 533–541, 2009.
- [17] *Personal Care Robots—Part 1: Physical Assistant Robots for Lumbar Support*, Standard JIS B 8456-1, 2017 (in Japanese).
- [18] Laevo B.V., Delft, The Netherlands, "Laevo V2." 2015. [Online]. Available: <http://en.laevo.nl/laevo-v2-product-information/>